

Strongman Tools

Clifton Club Platform Scissor Lift

Uses 240v single phase power

Lifts vehicles up to 3000 kg

Mobile, if required. Affords Centre Access



The *new* Clifton Club is our top spec surface mounted Mid-Rise Platform Scissor Lift. Designed to utilise an advanced assisted fulcrum this lift is effortless in operation and provides 'Two Stage Lowering' and secure ratchet safety systems, for the smoothest, most secure and reliable lift yet! Undoubtedly the class leader in terms of build quality, employing top grade steel and the best quality welds, compared to competitive product our price/performance easily surpasses all other lifts of this type making it the clear choice for your workshop.

The Clifton Club is extremely flexible and caters for the widest variety of cars & light vans, supplied complete with two sets of sturdy rubber lifting blocks. This model provides flexible lifting options from a platform 500mm wide and 1455mm long, a version of this lift which will offer the ability to lift off extended up-ramps is in development.

Designed to be used in a wide variety of applications, it is suitable as a mid-rise ramp for body-shops; tyre, brake and suspension workshops; as an additional ramp to fit into the corner of a larger workshop; for areas where head height is restricted; for use as the main ramp for start-up businesses or as an ideal tool in the home workshop! It uses a single synchronising bar and provides a robust and stable base for all your maintenance jobs, from changing the oil to replacing a gearbox!

These lifts can be left in-situ, as a "drive-over", are powered by 240V 16A single phase supply equipped with a motor rated breaker, they lift a vehicle up to 3000kg to any height up to a metre. They employ short run up ramps and have a maximum 110mm profile when down. Clifton lifts have CE safety certification and can be supplied as a fully mobile unit, with optional casters and movement handle .



Specifications	
Lift Load	3000 kg
Max. Lift Height	1000 mm
Ramp Length	1455 mm
Overall Length	2035 mm
Overall Width	2100 mm inc. toe protectors
Minimum Clearance	110 mm
Ramp Width	500 mm
Working Gap between ramps	810 mm
Up-ramp Length	290 mm
Lift Weight	550 kg
Motor	240V single Ø
Supply needed	16A
Circuit breaker	C or D rated required
Locking mechanism	Ratchet system, Air Release

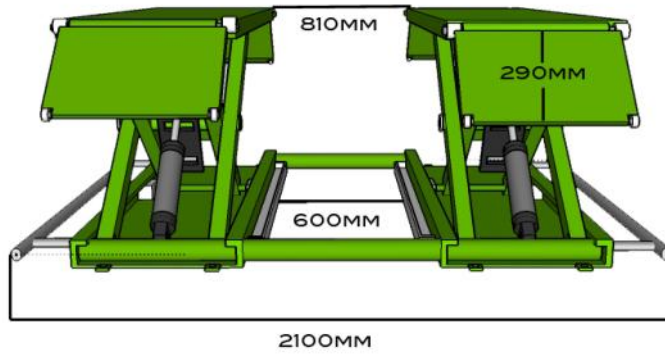
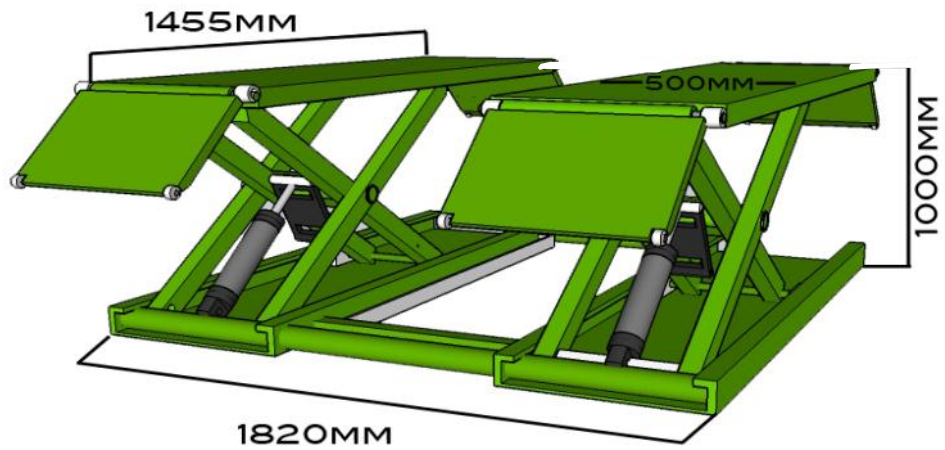

Clockwise, photos show: Complete centre access available; detail of ratchet safety system; assisted fulcrum employed provides 3000kg capacity; Landrover Discovery raised, wheels free; vehicle lifted to 1m perfect for workshops with limited head-height, for use in a domestic garage or as an additional ramp in franchised workshops or tyre / exhaust bays.



tel: 01926 453 047
www.strongmantools.co.uk

Strongman Tools Ltd
 Berrington Road
 Leamington Spa
 Warwickshire
 CV31 1NB